

*Abecedario en cursiva*  
*Cuadernillo de Ejercicios*  
*Maestra Judith*

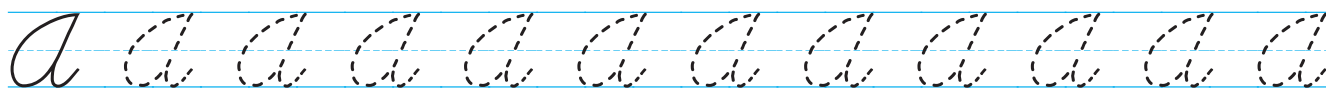

*maestrajudith.com*

Empieza el trazo como te indica la flecha.  
Realiza los ejercicios, tomando como base la línea punteada.

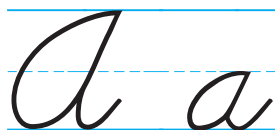
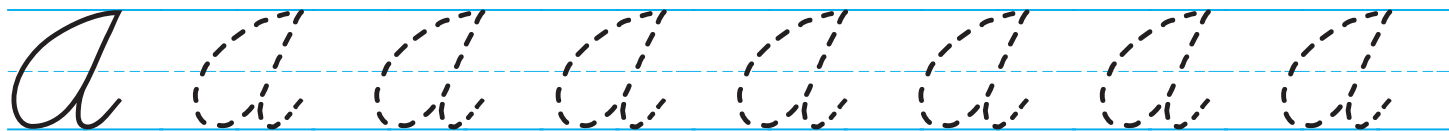
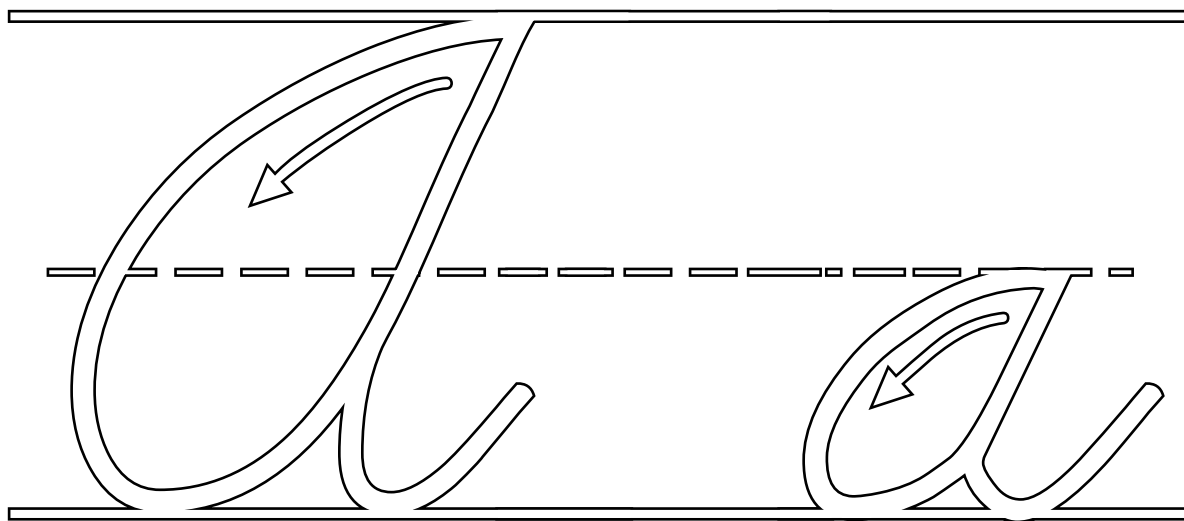

Empieza el trazo como te indica la flecha.

Realiza los ejercicios, tomando como base la línea punteada.

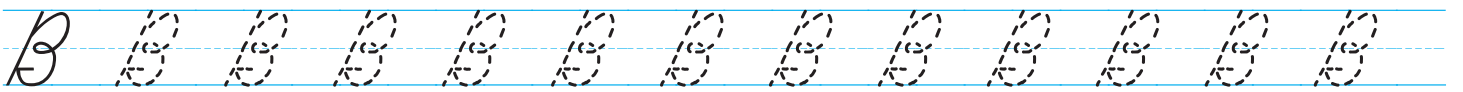
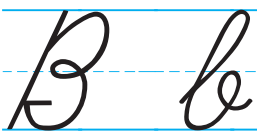
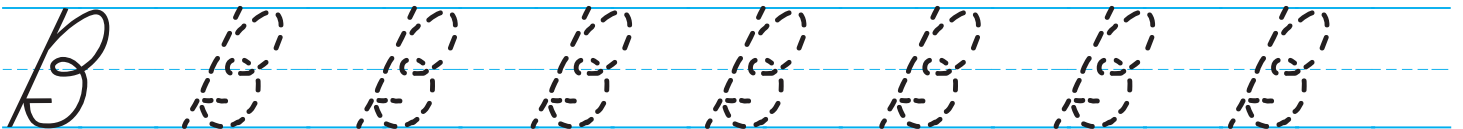
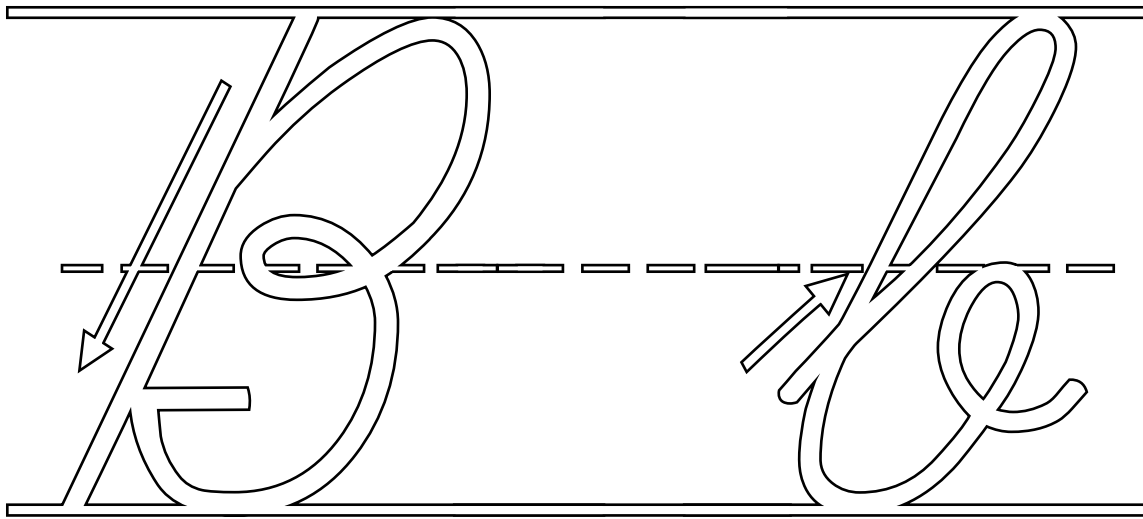

Empieza el trazo como te indica la flecha.

Realiza los ejercicios, tomando como base la línea punteada.

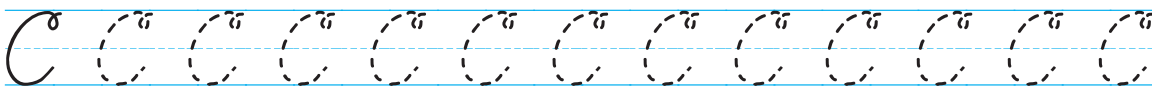
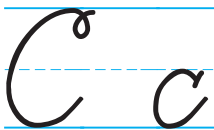
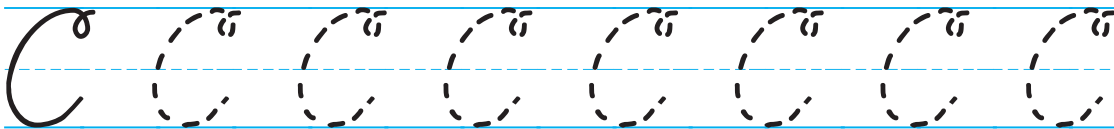
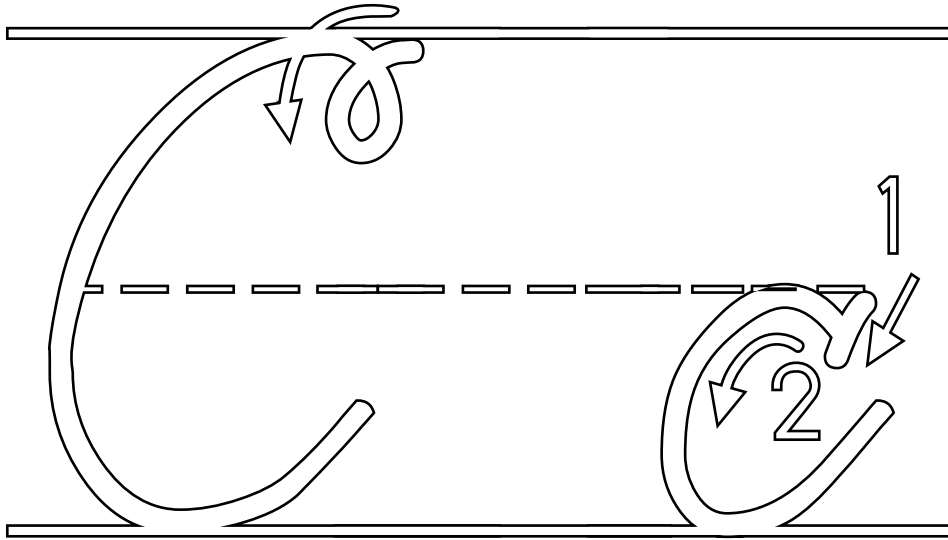

Empieza el trazo como te indica la flecha.

Realiza los ejercicios, tomando como base la línea punteada.

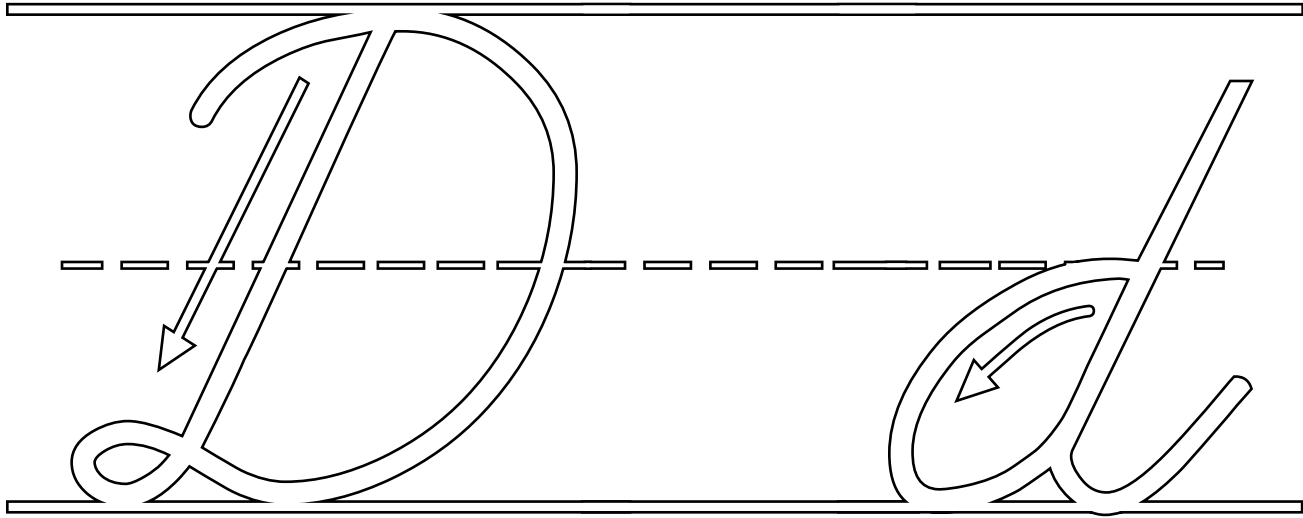

D D D D D D D

d d d d d d d d

D d

D D D D D D D D D D

d d d d d d d d d d d d



Empieza el trazo como te indica la flecha.

Realiza los ejercicios, tomando como base la línea punteada.

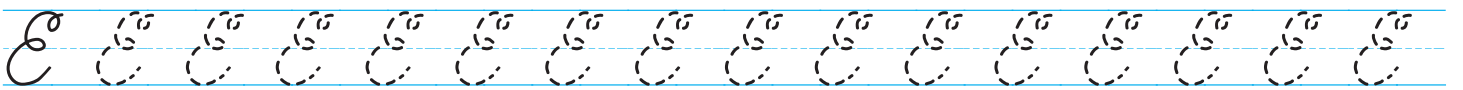
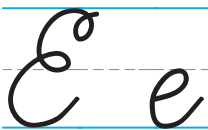
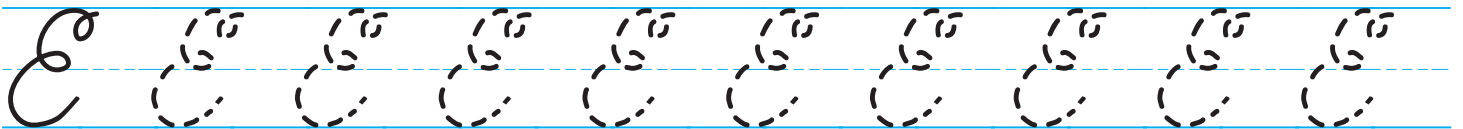
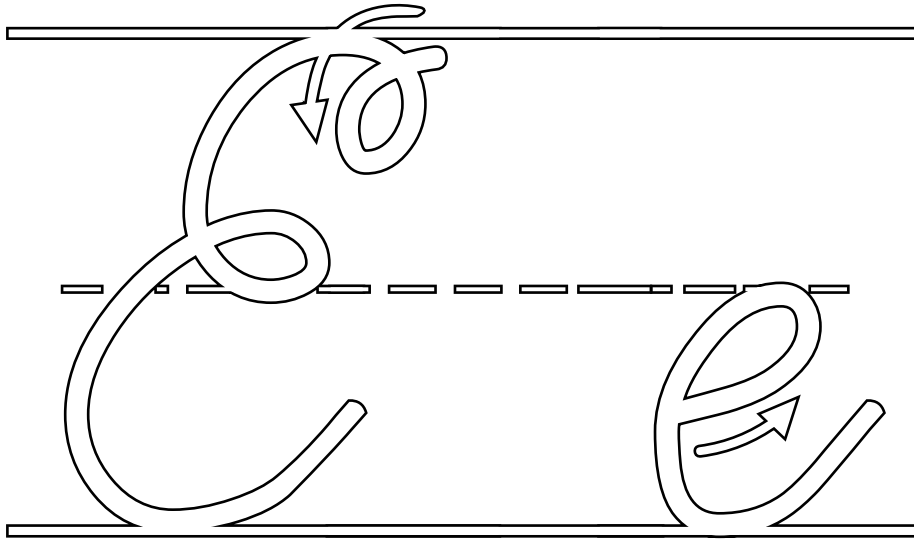

Empieza el trazo como te indica la flecha.

Realiza los ejercicios, tomando como base la línea punteada.

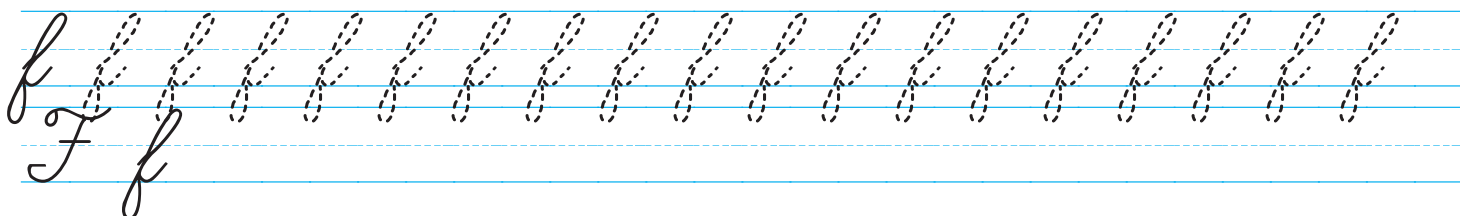
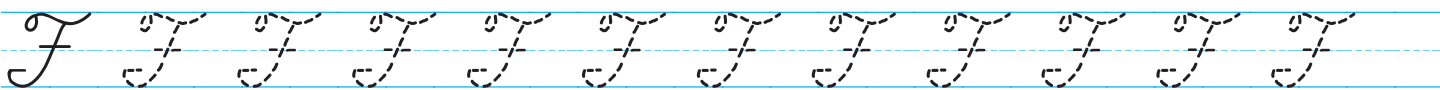
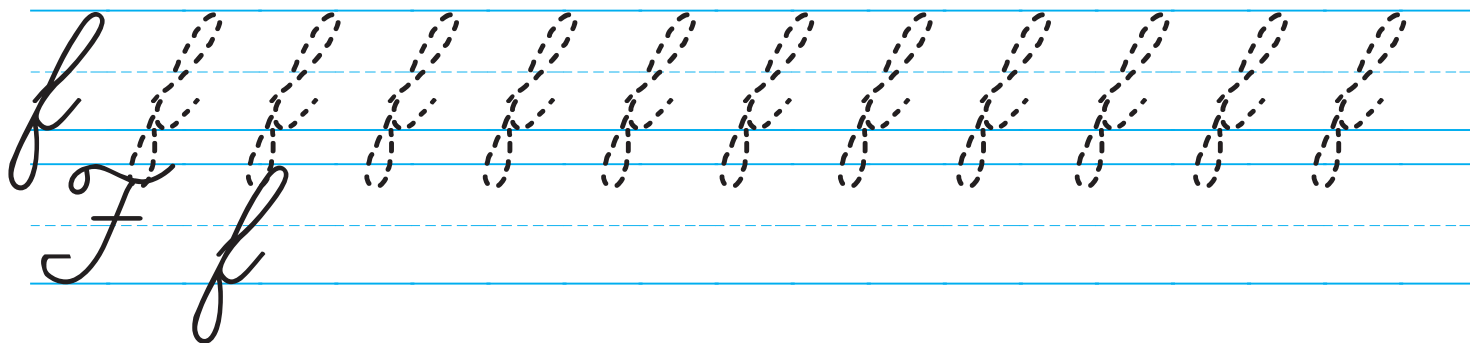
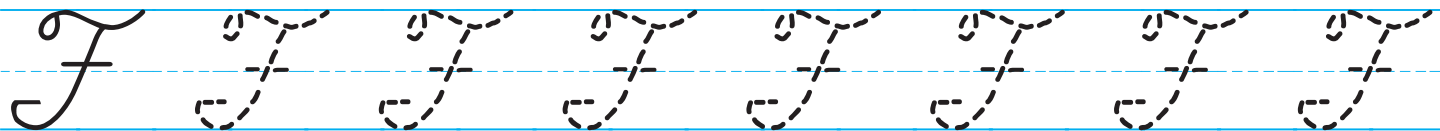
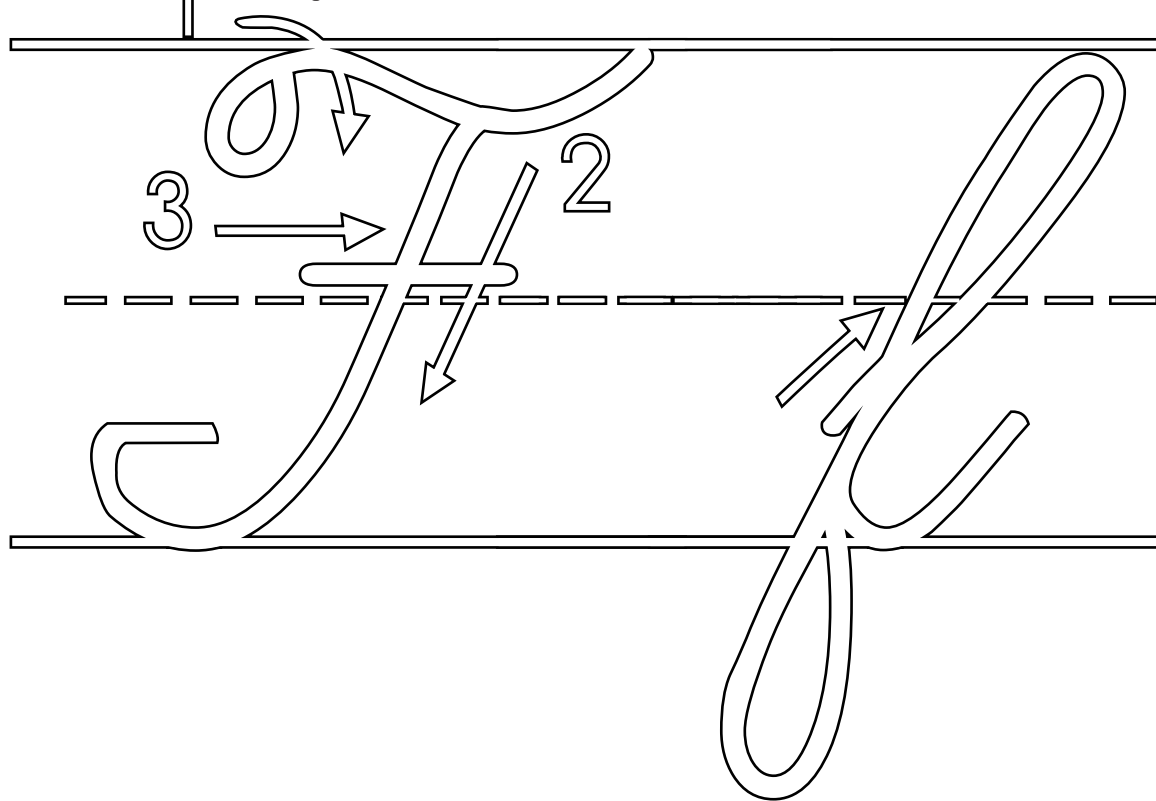

Empieza el trazo como te indica la flecha.

Realiza los ejercicios, tomando como base la línea punteada.

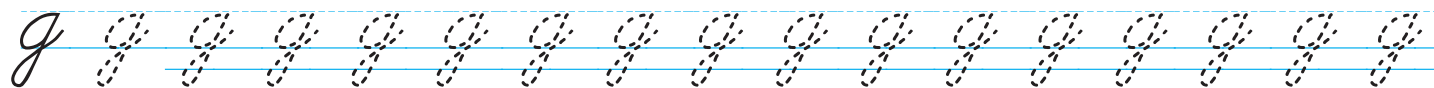
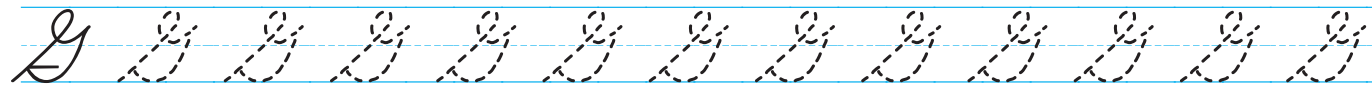
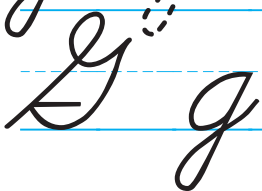
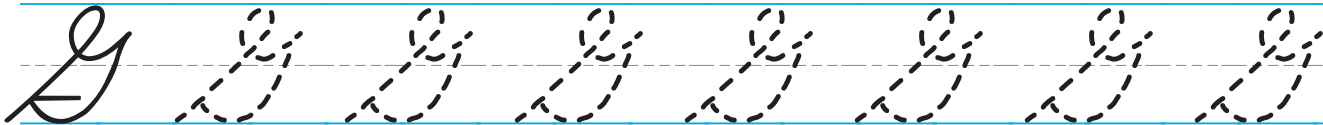
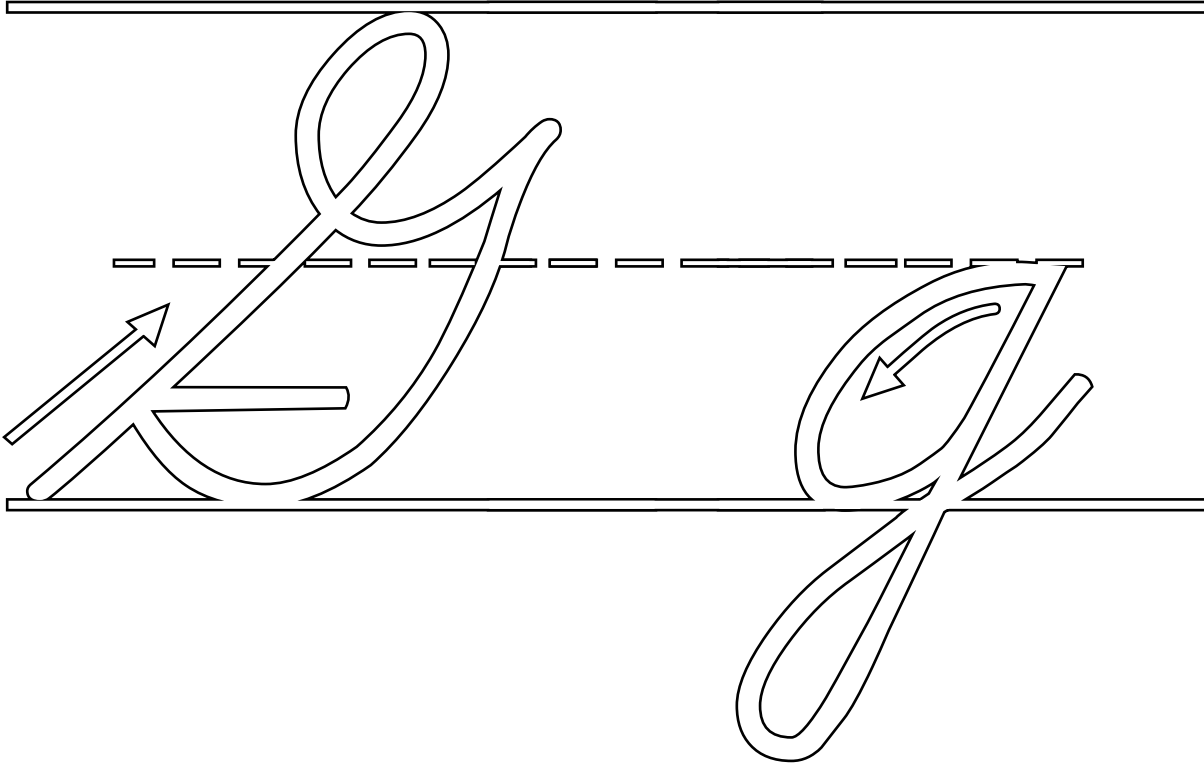



Empieza el trazo como te indica la flecha.

Realiza los ejercicios, tomando como base la línea punteada.

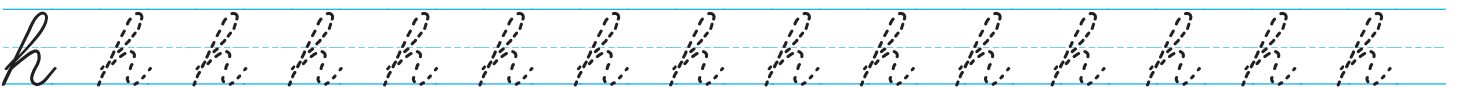
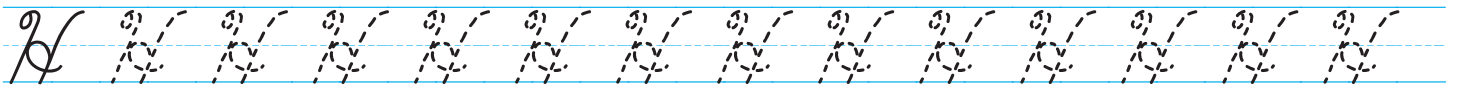
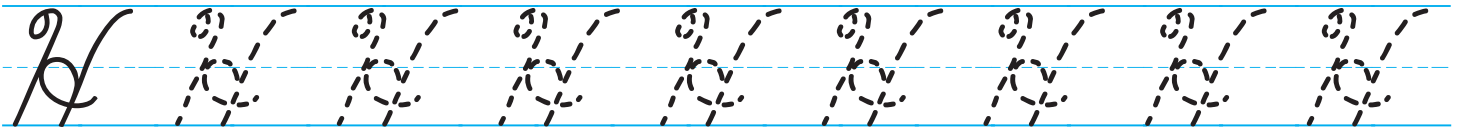
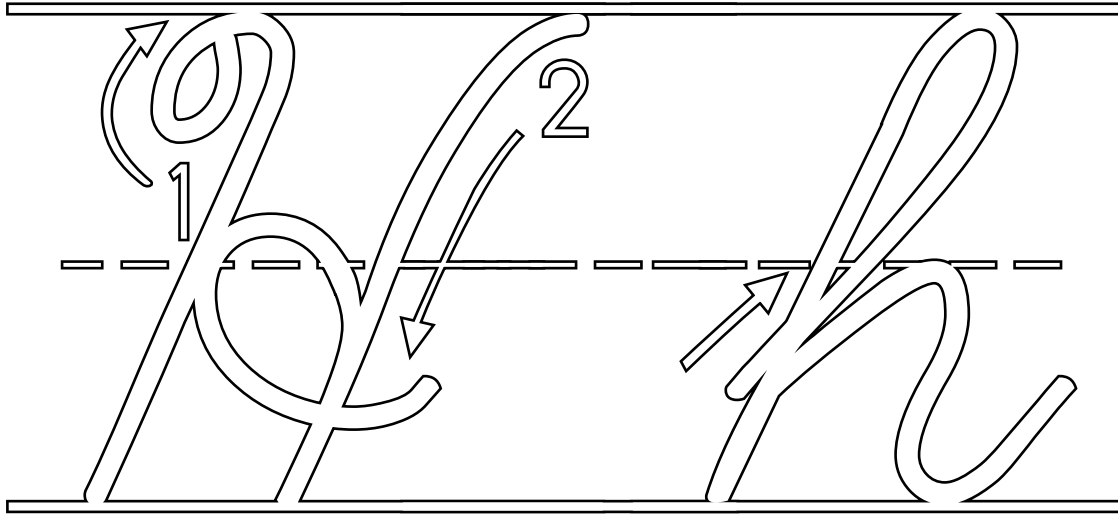

Empieza el trazo como te indica la flecha.

Realiza los ejercicios, tomando como base la línea punteada.

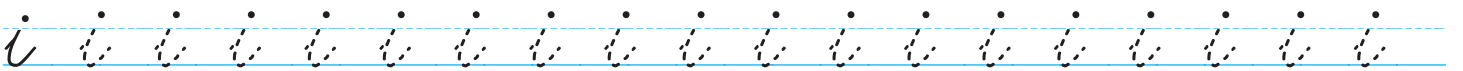
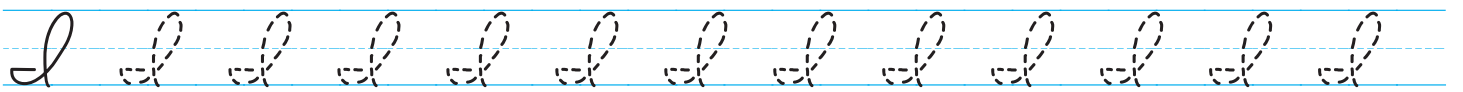
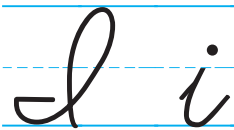
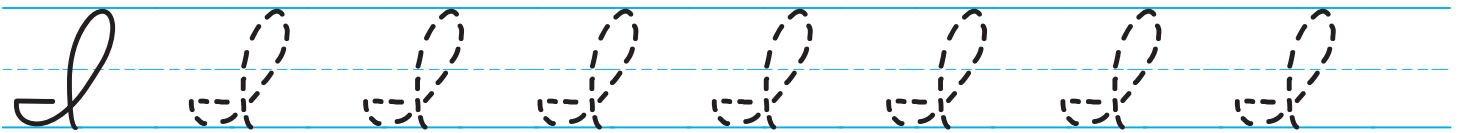
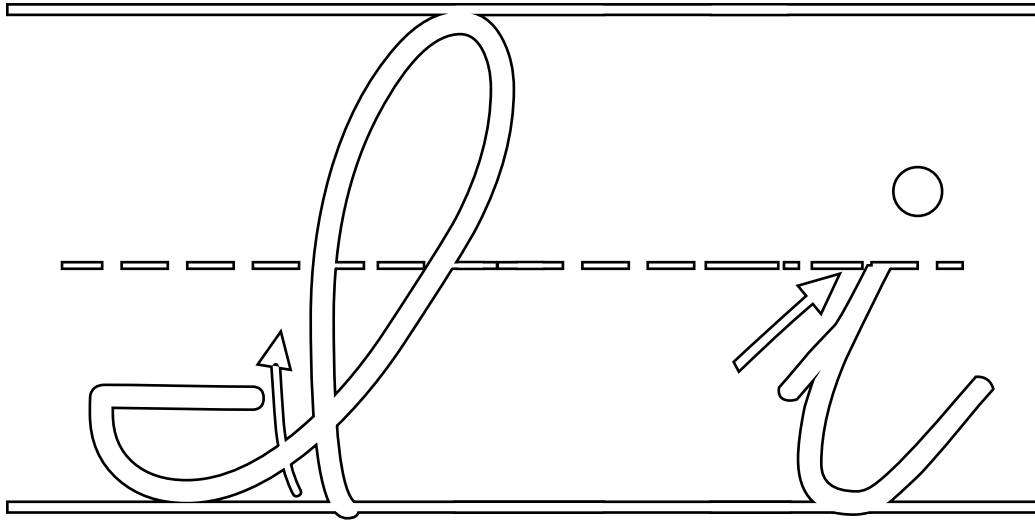

Empieza el trazo como te indica la flecha.  
Realiza los ejercicios, tomando como base la línea punteada.

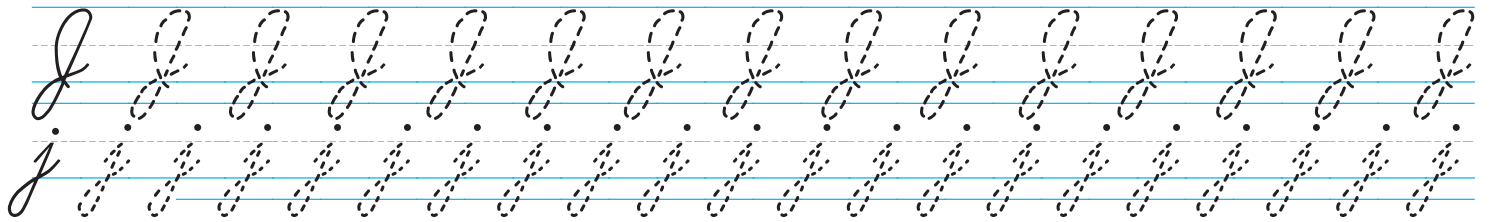
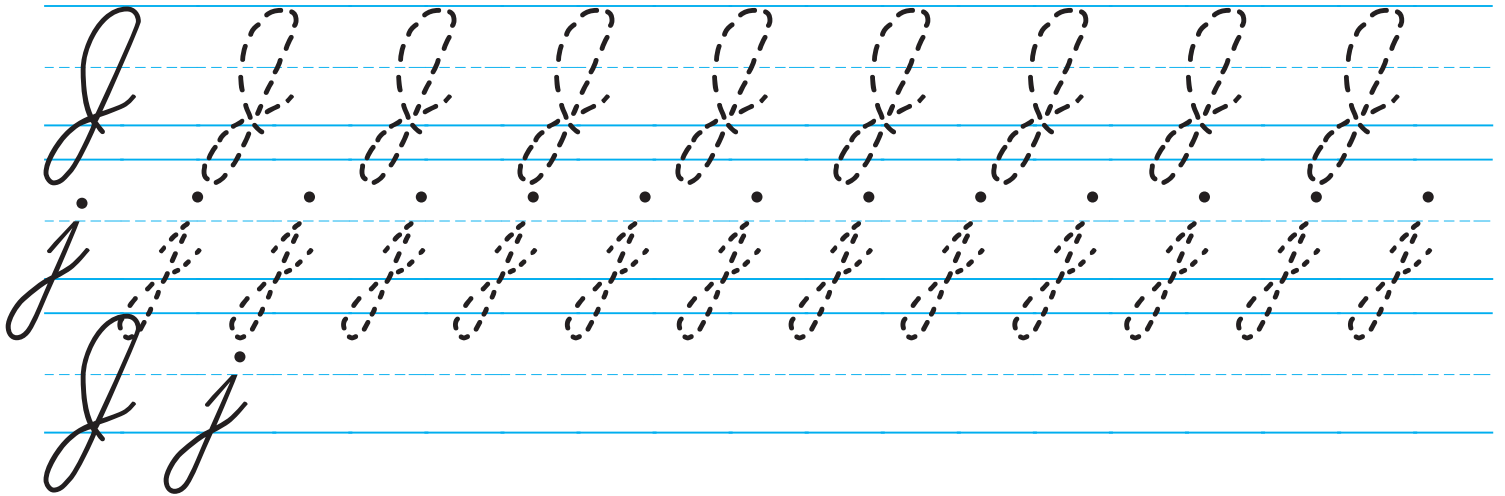
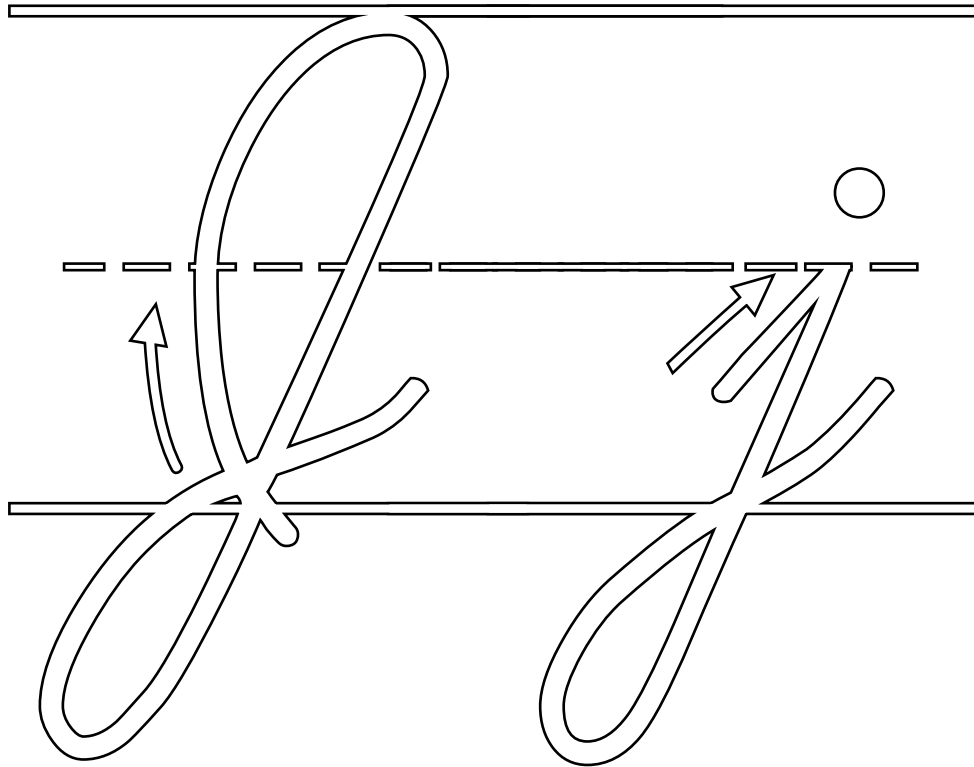

Empieza el trazo como te indica la flecha.

Realiza los ejercicios, tomando como base la línea punteada.

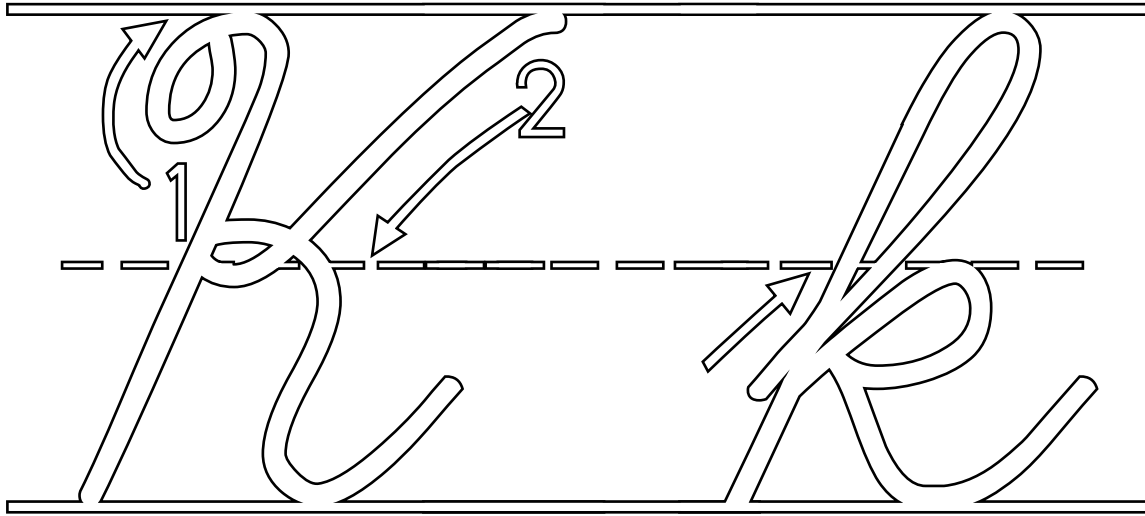

K K K K K K K K K

k k k k k k k k k

K k

K K K K K K K K K K K K K

k k k k k k k k k k k k k

K k



Empieza el trazo como te indica la flecha.

Realiza los ejercicios, tomando como base la línea punteada.

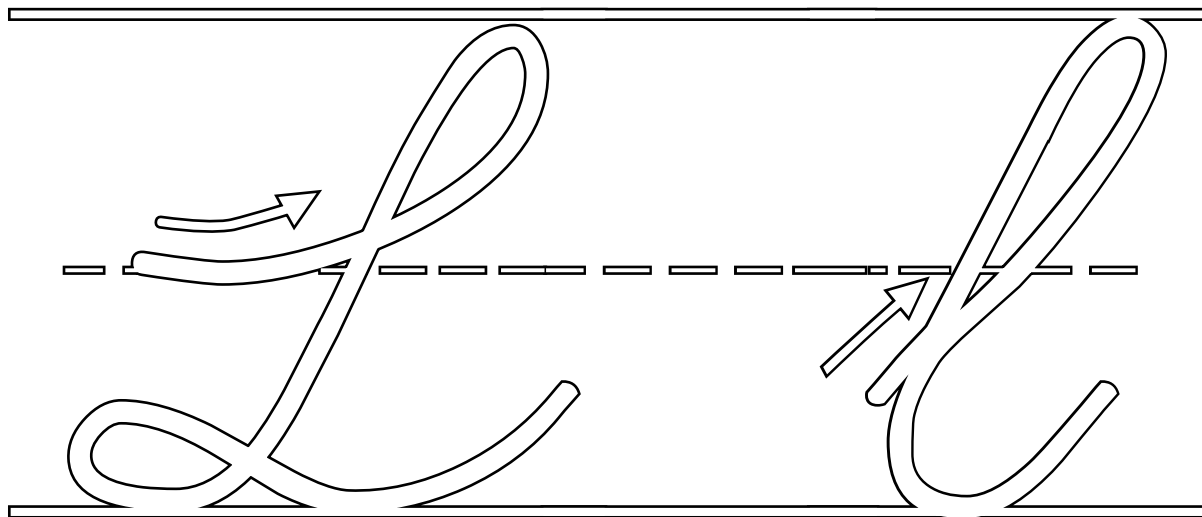

L L L L L L L L

l l l l l l l l l l

L l

L L L L L L L L L L L L

l l l l l l l l l l l l l l

L l



Empieza el trazo como te indica la flecha.

Realiza los ejercicios, tomando como base la línea punteada.

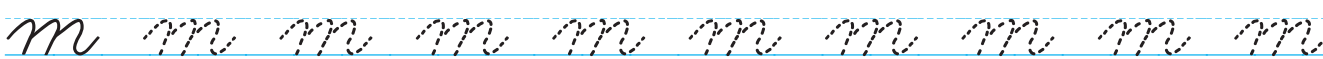
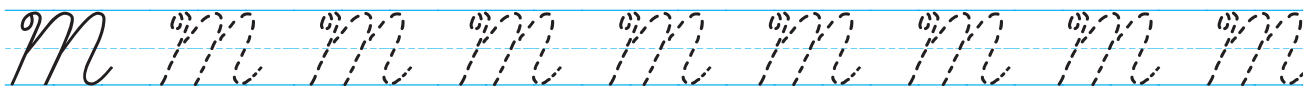
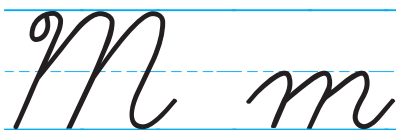
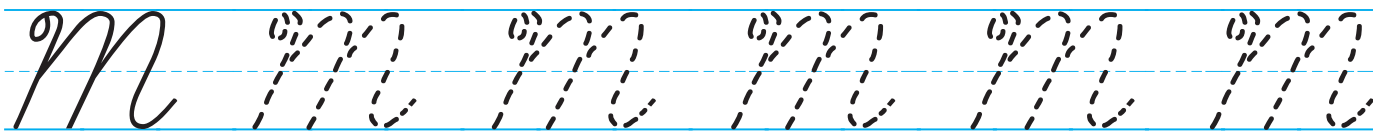
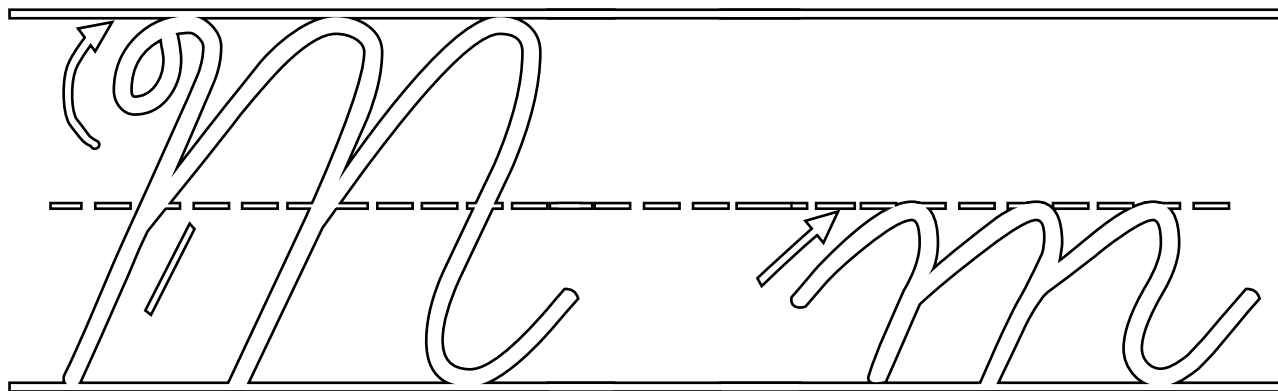

Empieza el trazo como te indica la flecha.

Realiza los ejercicios, tomando como base la línea punteada.

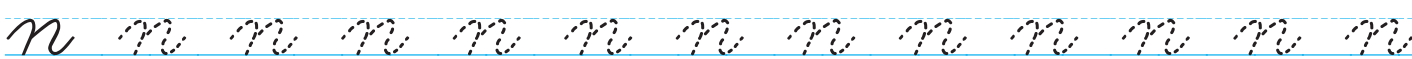
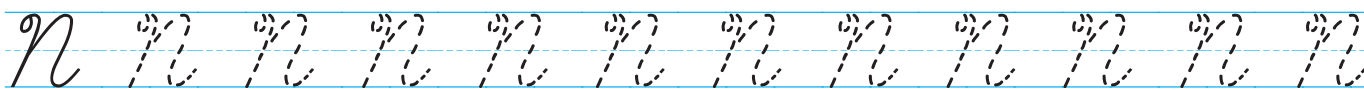
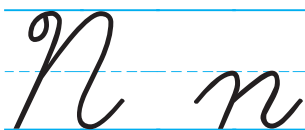
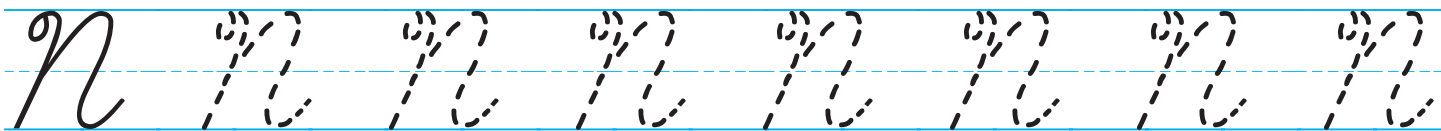
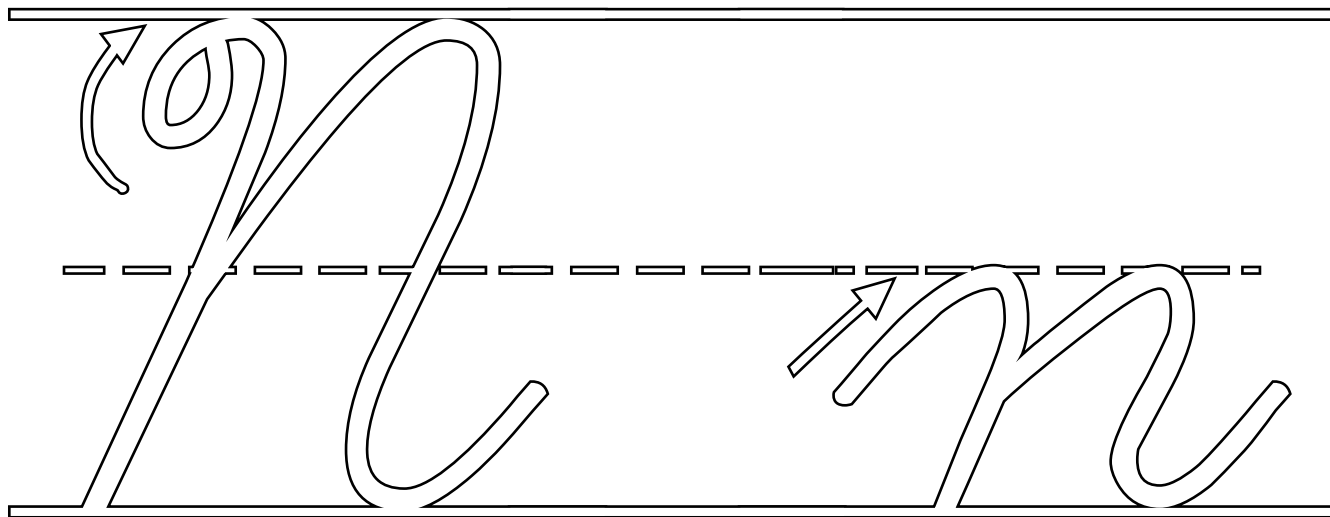

Empieza el trazo como te indica la flecha.  
Realiza los ejercicios, tomando como base la línea punteada.

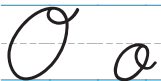
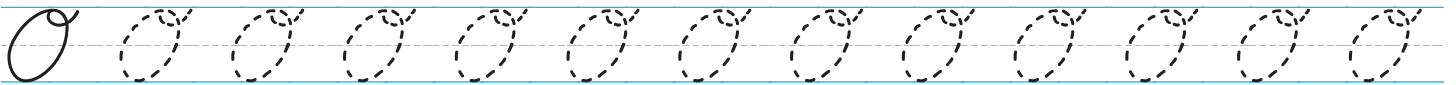
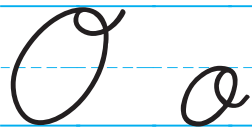
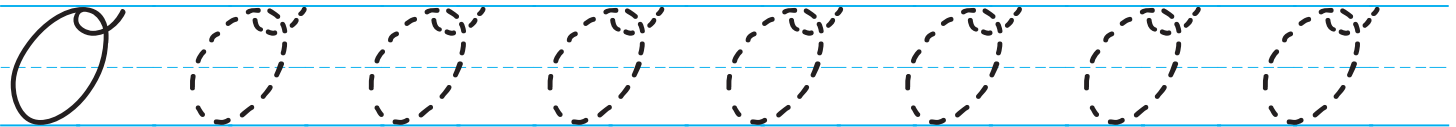
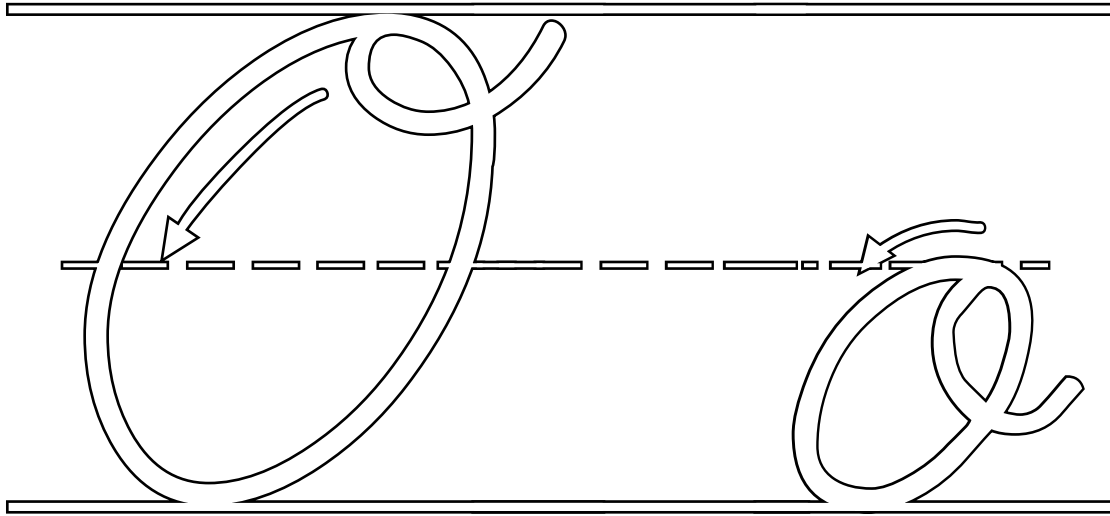



Empieza el trazo como te indica la flecha.  
Realiza los ejercicios, tomando como base la línea punteada.

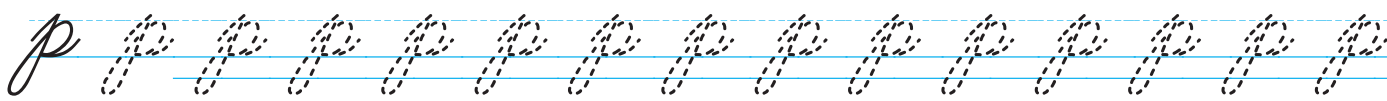
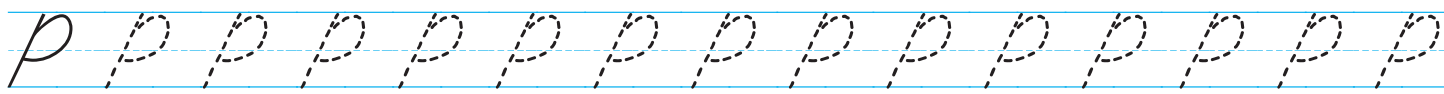
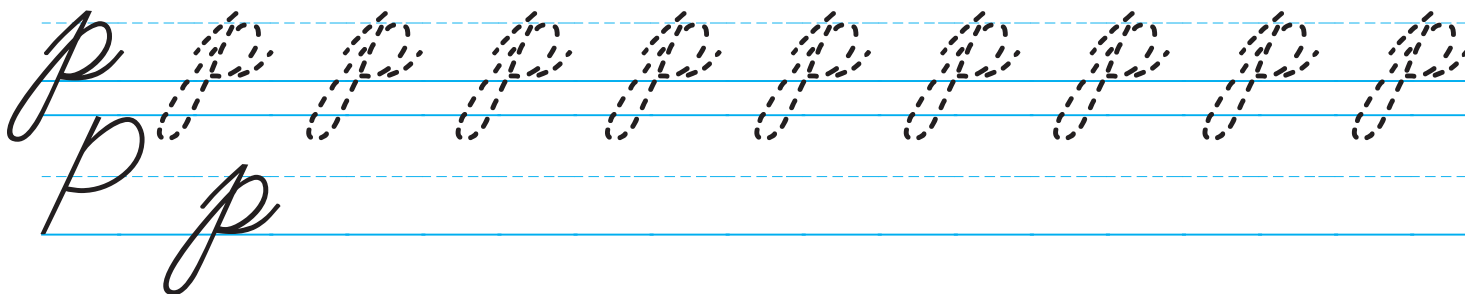
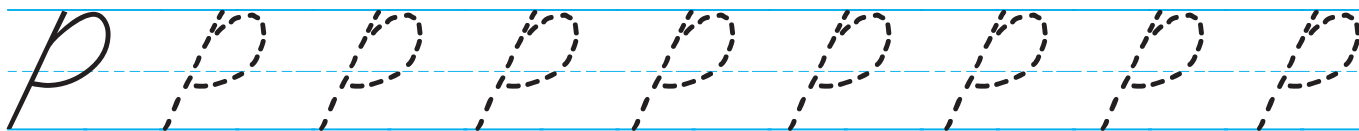
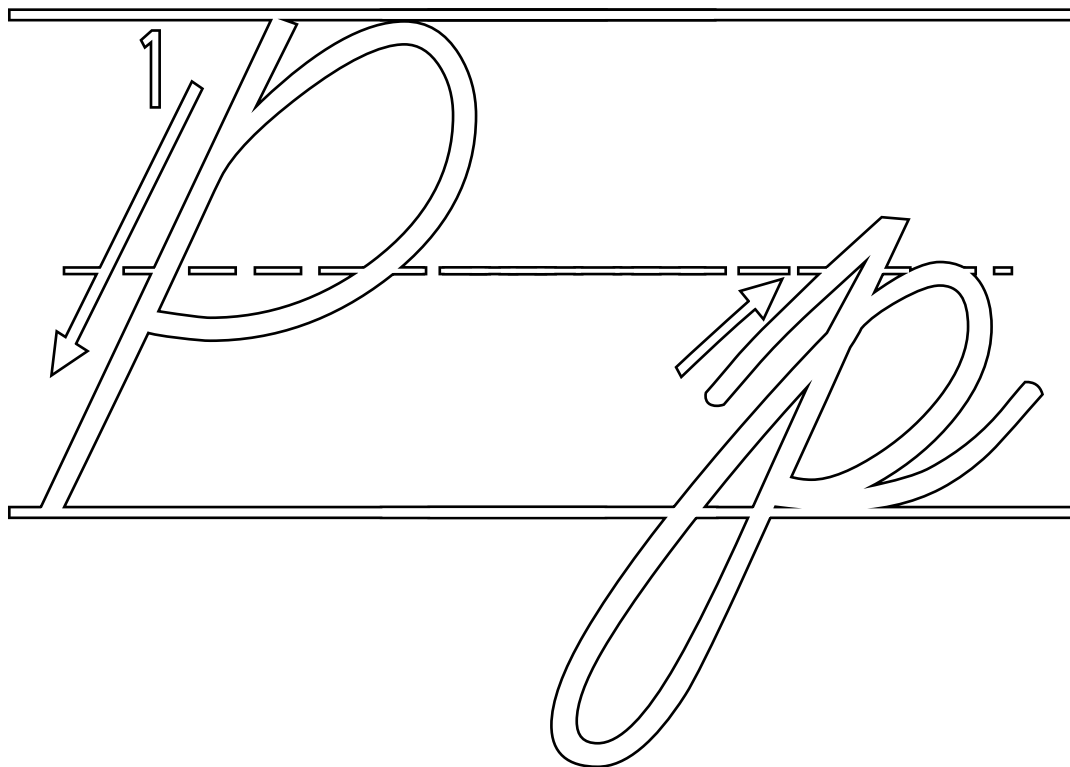

Empieza el trazo como te indica la flecha.

Realiza los ejercicios, tomando como base la línea punteada.

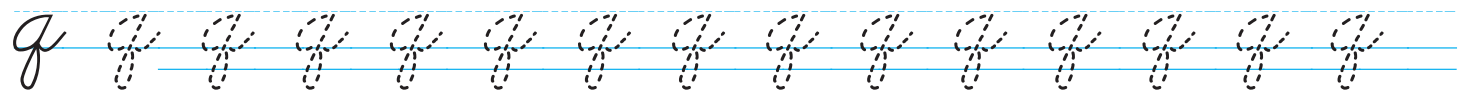
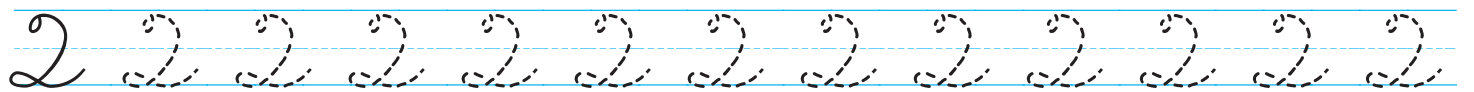
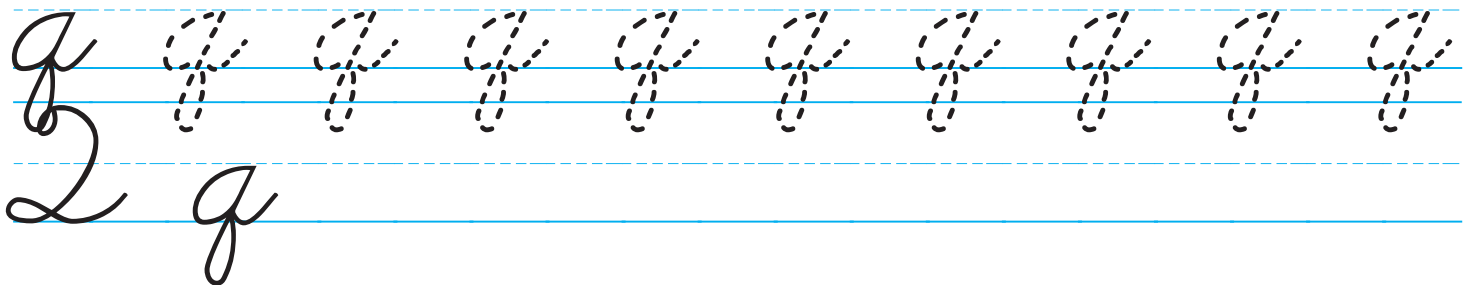
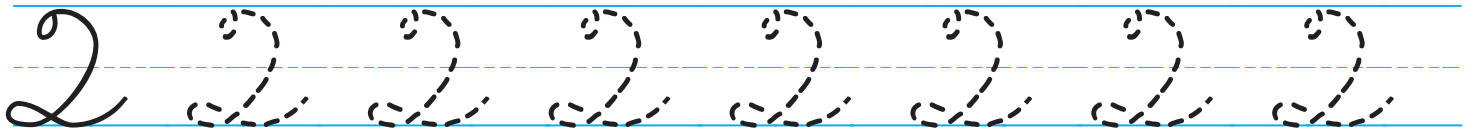
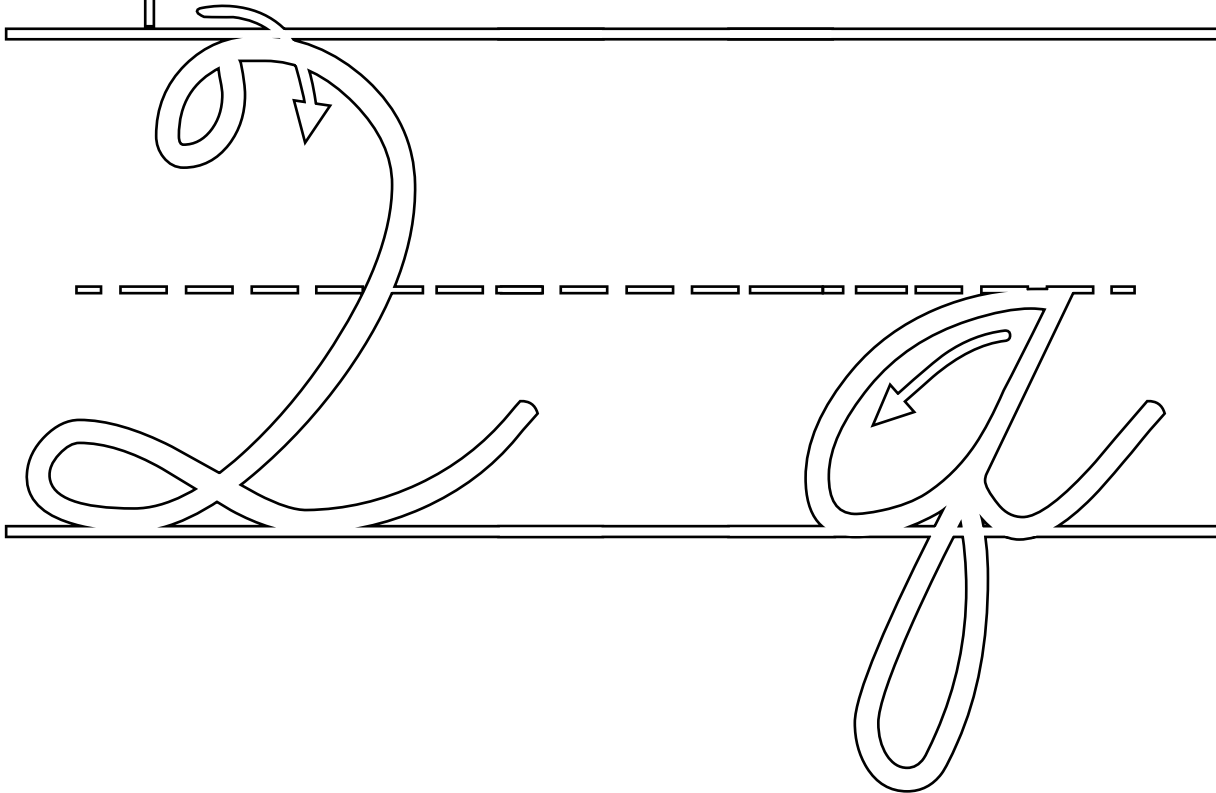

Empieza el trazo como te indica la flecha.

Realiza los ejercicios, tomando como base la línea punteada.

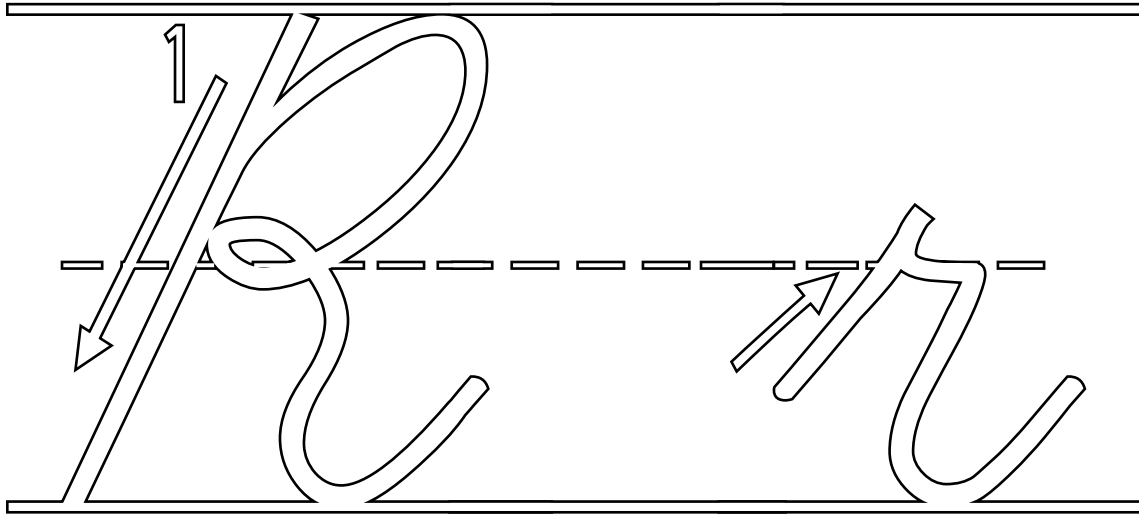

R R R R R R R R

r r r r r r r r r r

R r

R R R R R R R R R R R R R R

r r r r r r r r r r r r r r r



Empieza el trazo como te indica la flecha.

Realiza los ejercicios, tomando como base la línea punteada.

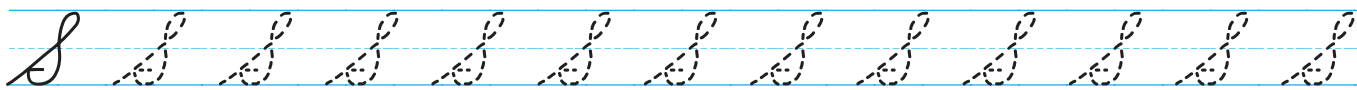
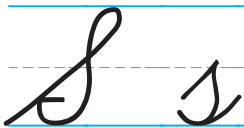
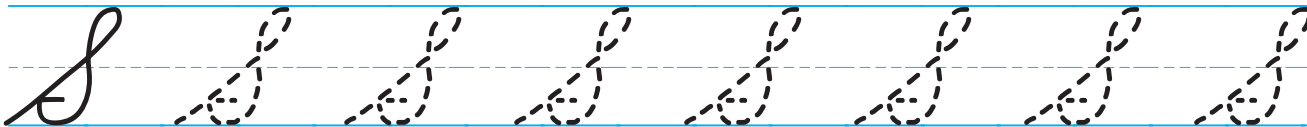
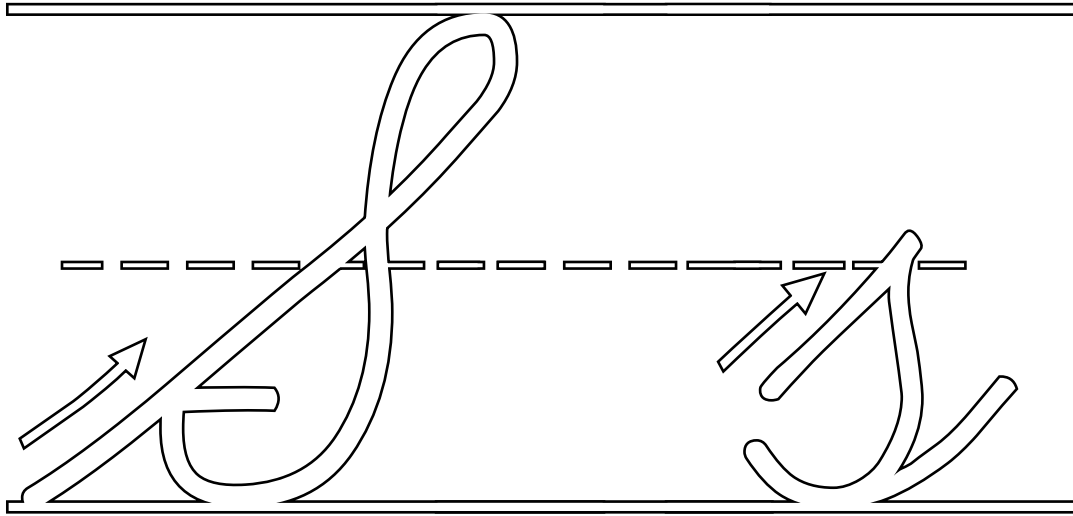

Empieza el trazo como te indica la flecha.

Realiza los ejercicios, tomando como base la línea punteada.

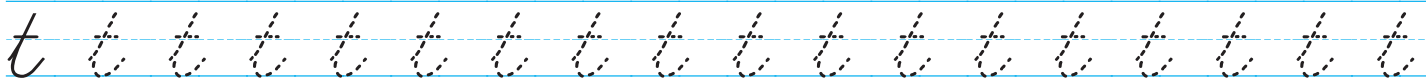
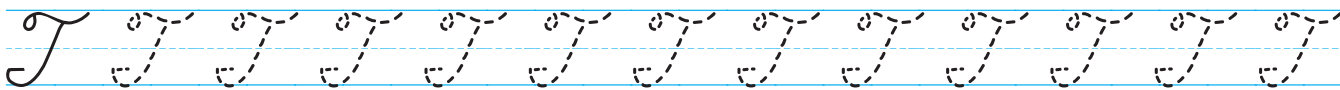
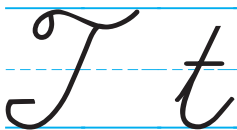
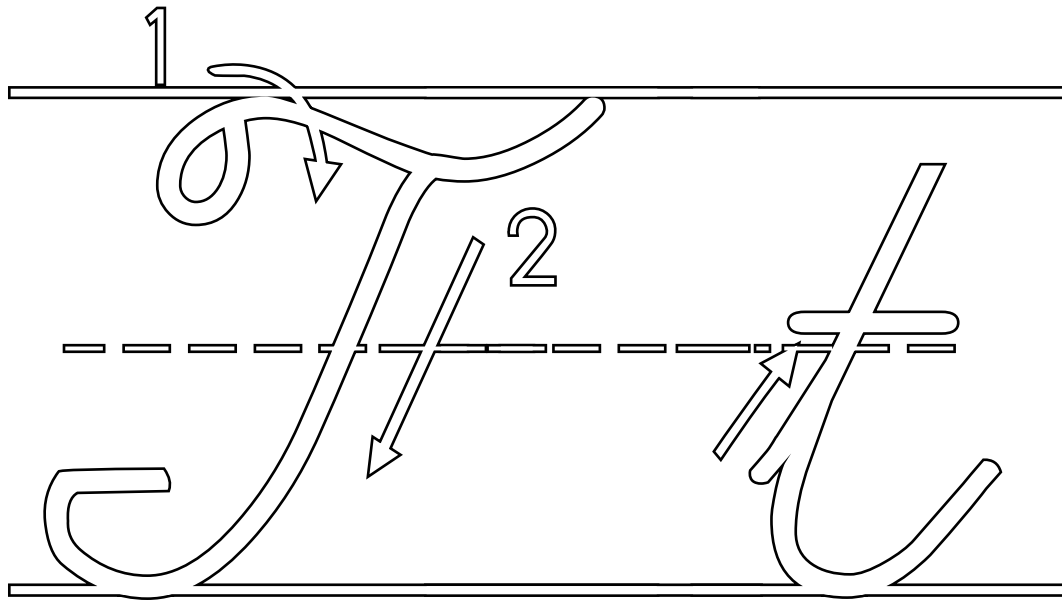

Empieza el trazo como te indica la flecha.

Realiza los ejercicios, tomando como base la línea punteada.

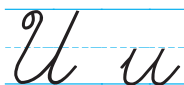
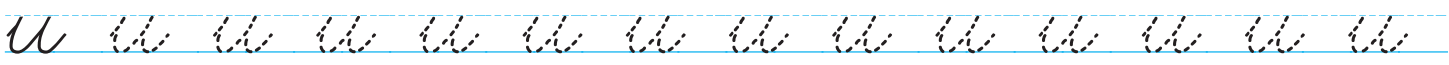
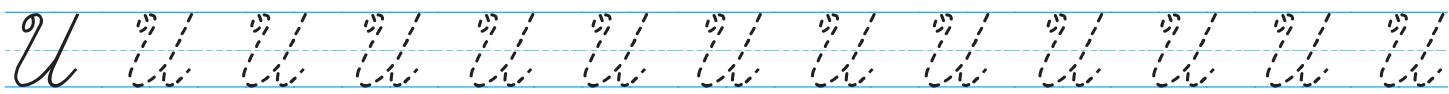
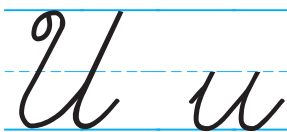
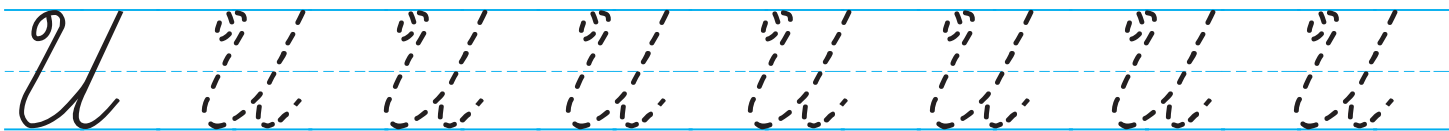
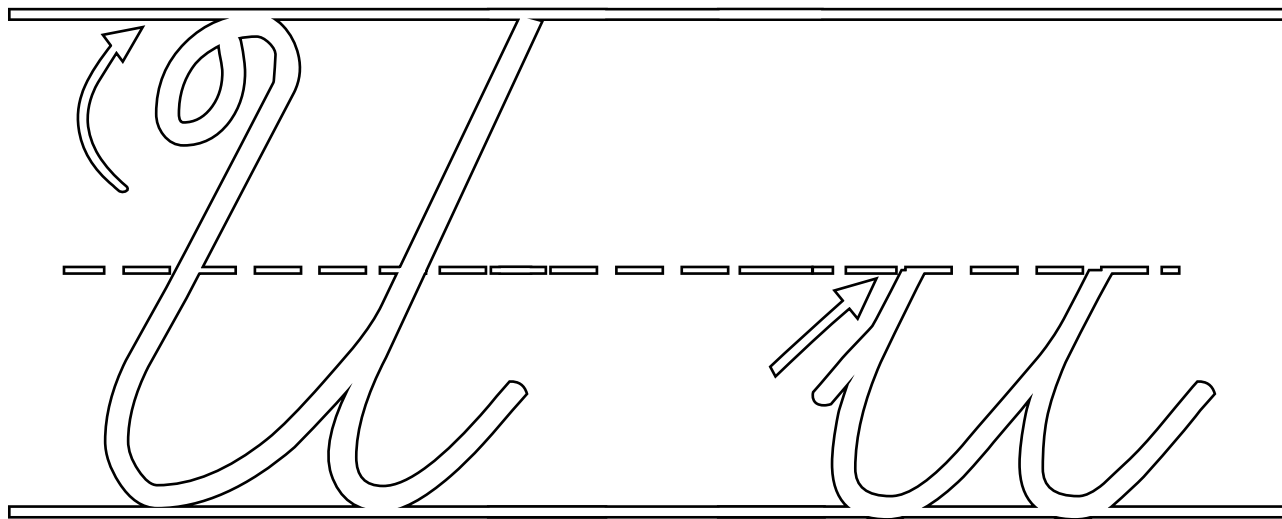

Empieza el trazo como te indica la flecha.

Realiza los ejercicios, tomando como base la línea punteada.

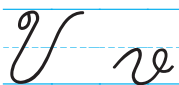
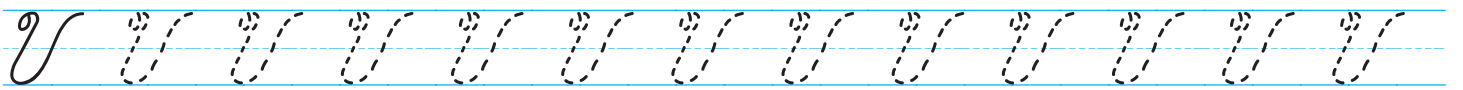
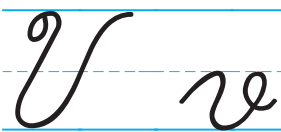
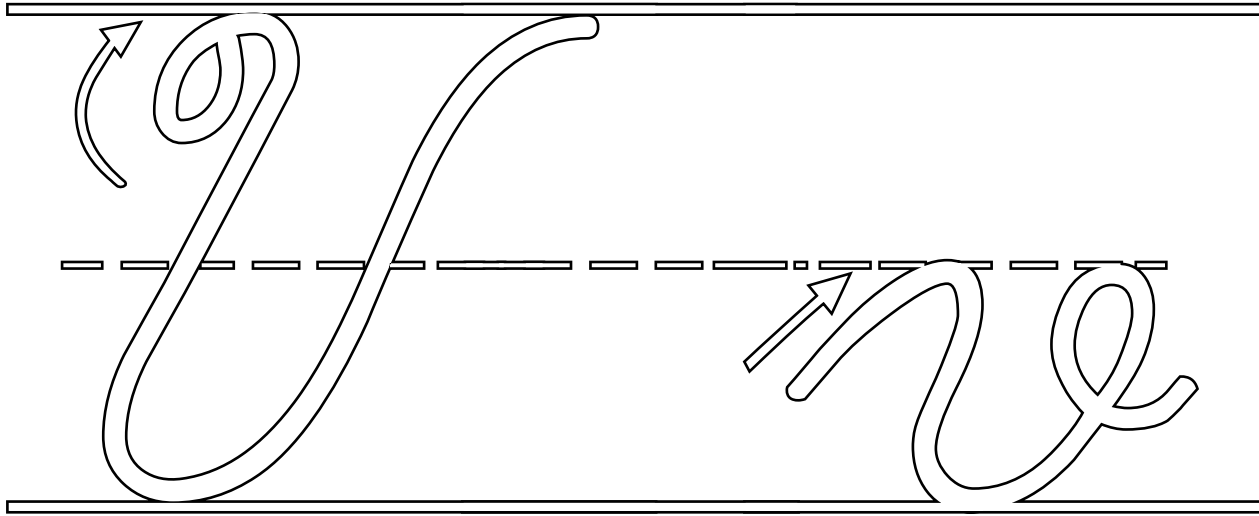

Empieza el trazo como te indica la flecha.

Realiza los ejercicios, tomando como base la línea punteada.

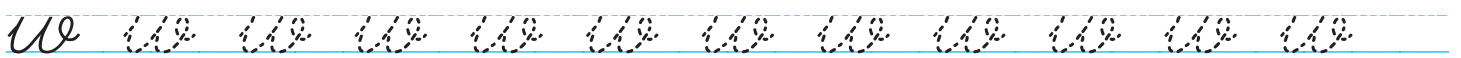
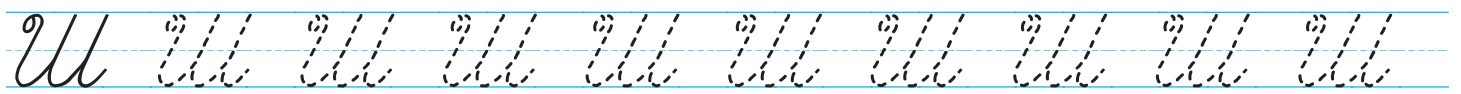
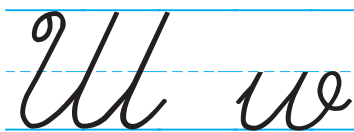
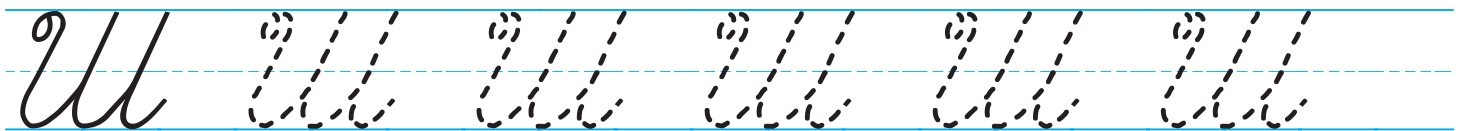
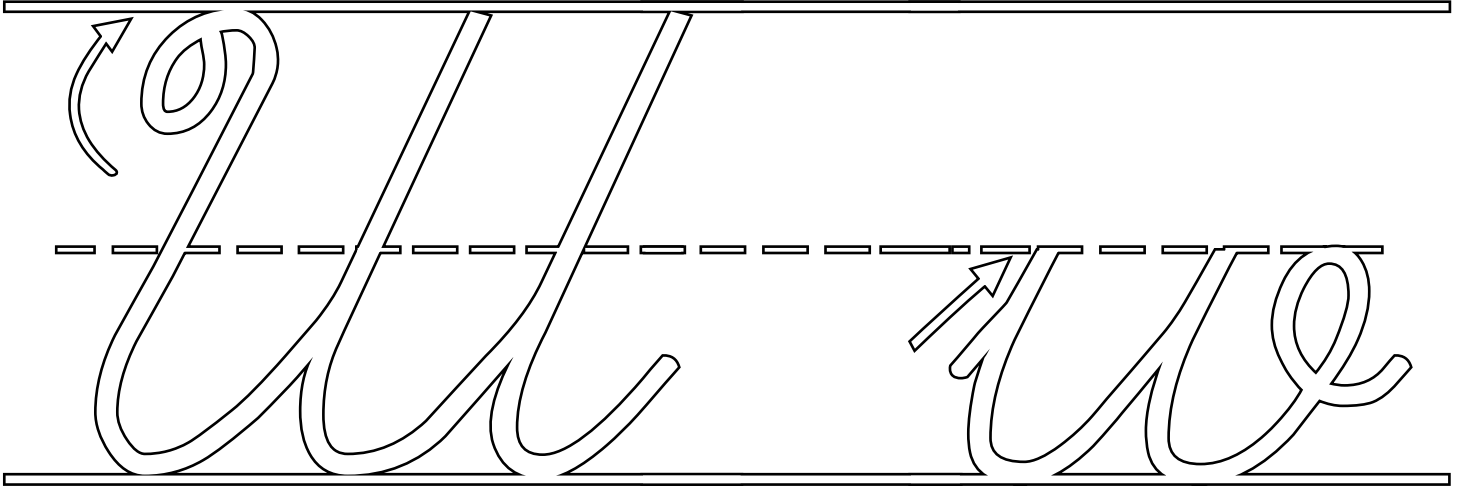



Empieza el trazo como te indica la flecha.

Realiza los ejercicios, tomando como base la línea punteada.

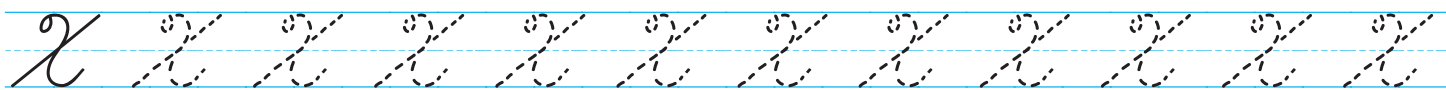
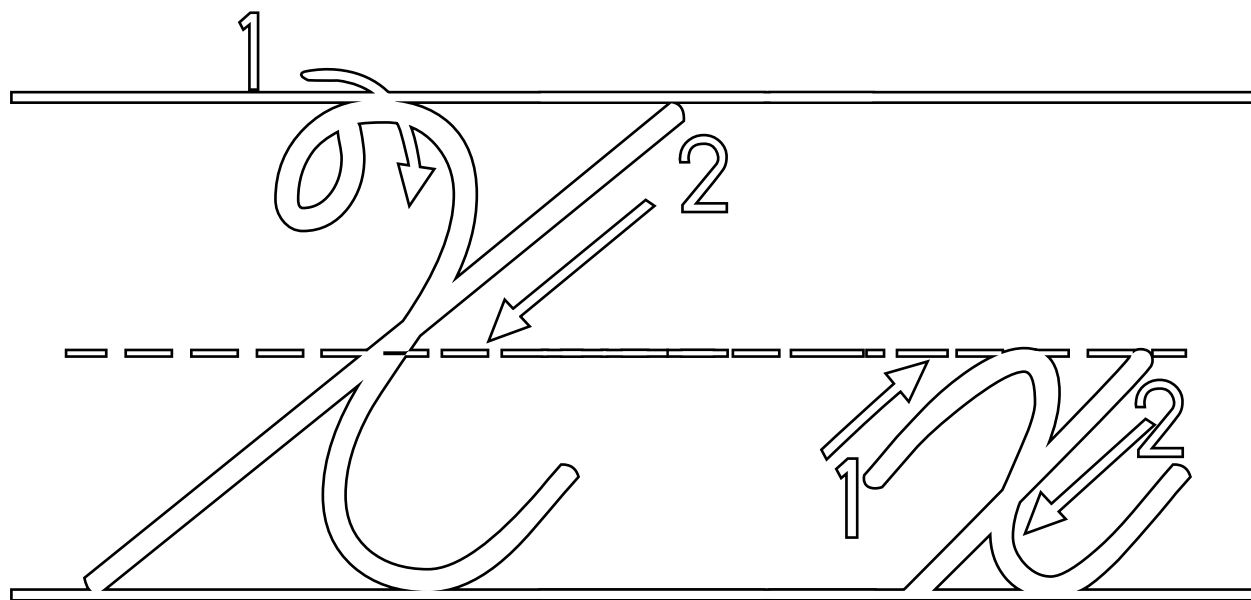

Empieza el trazo como te indica la flecha.

Realiza los ejercicios, tomando como base la línea punteada.

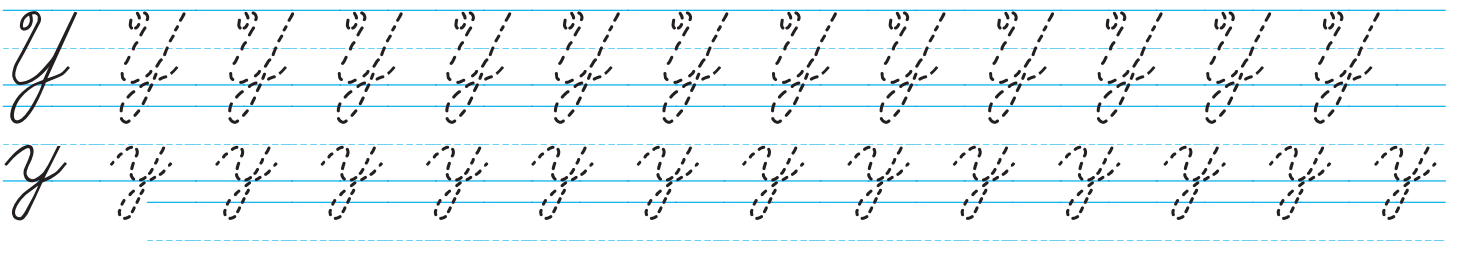
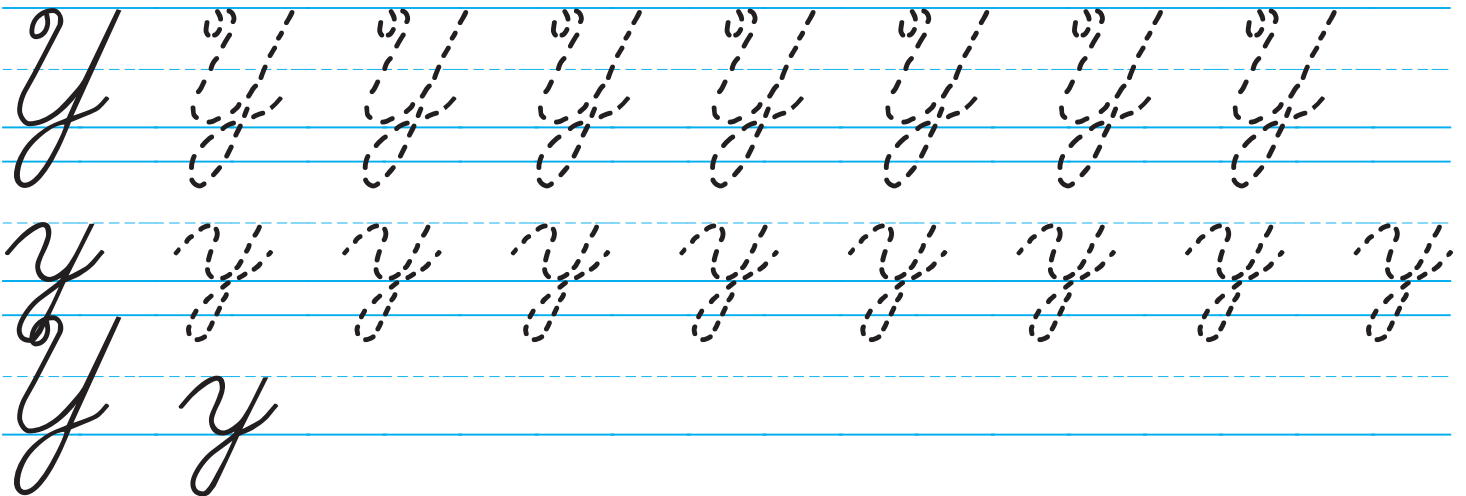
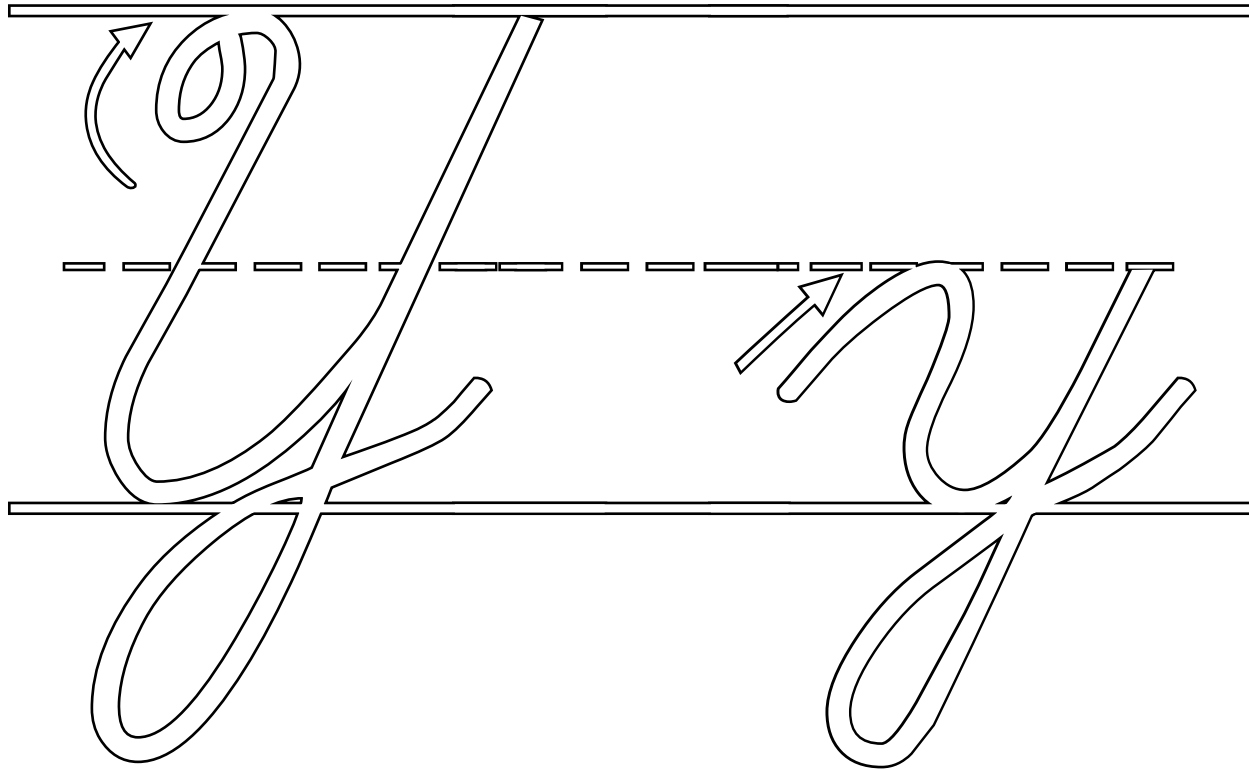

Empieza el trazo como te indica la flecha.  
Realiza los ejercicios, tomando como base la línea punteada.

